

VACUUM CLEANER ZELMER TYPE 5500.0H T AUSTRALIA

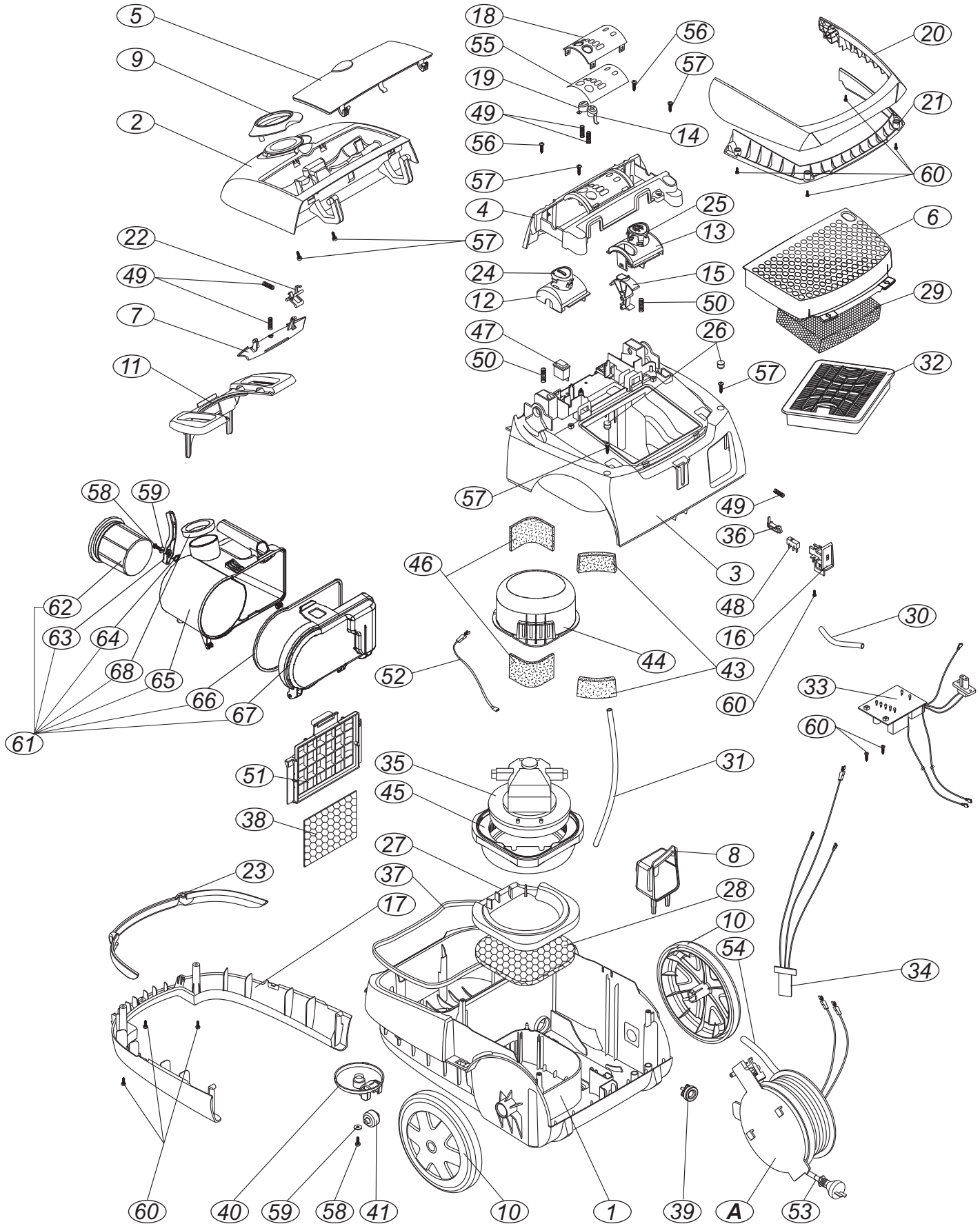

|| CORD WINDER 269.5100 AUSTRALIA

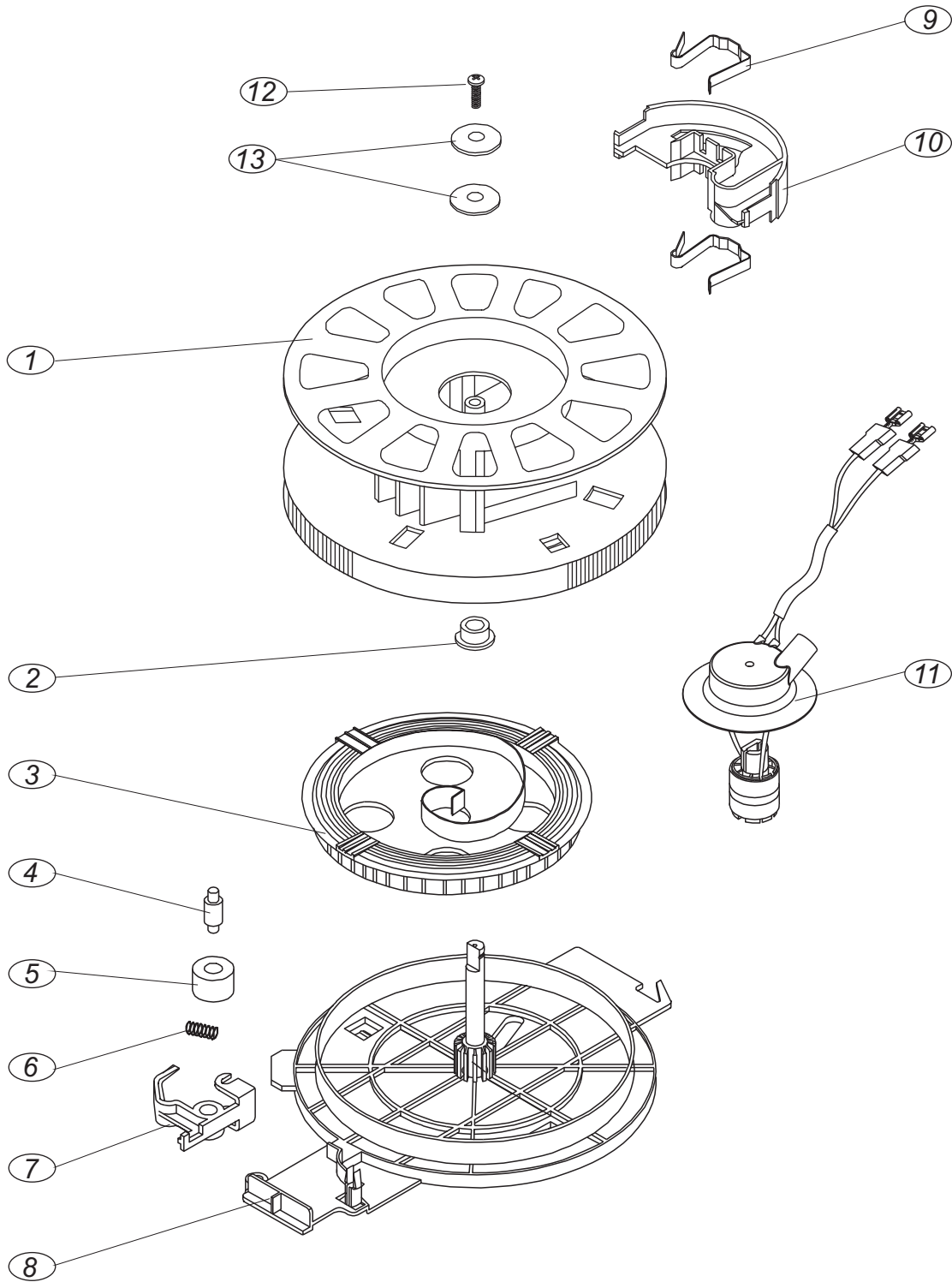

IV VACUUM CLEANER ACCESSORIES ZELMER TYPE 5500.0H T AUSTRALIA

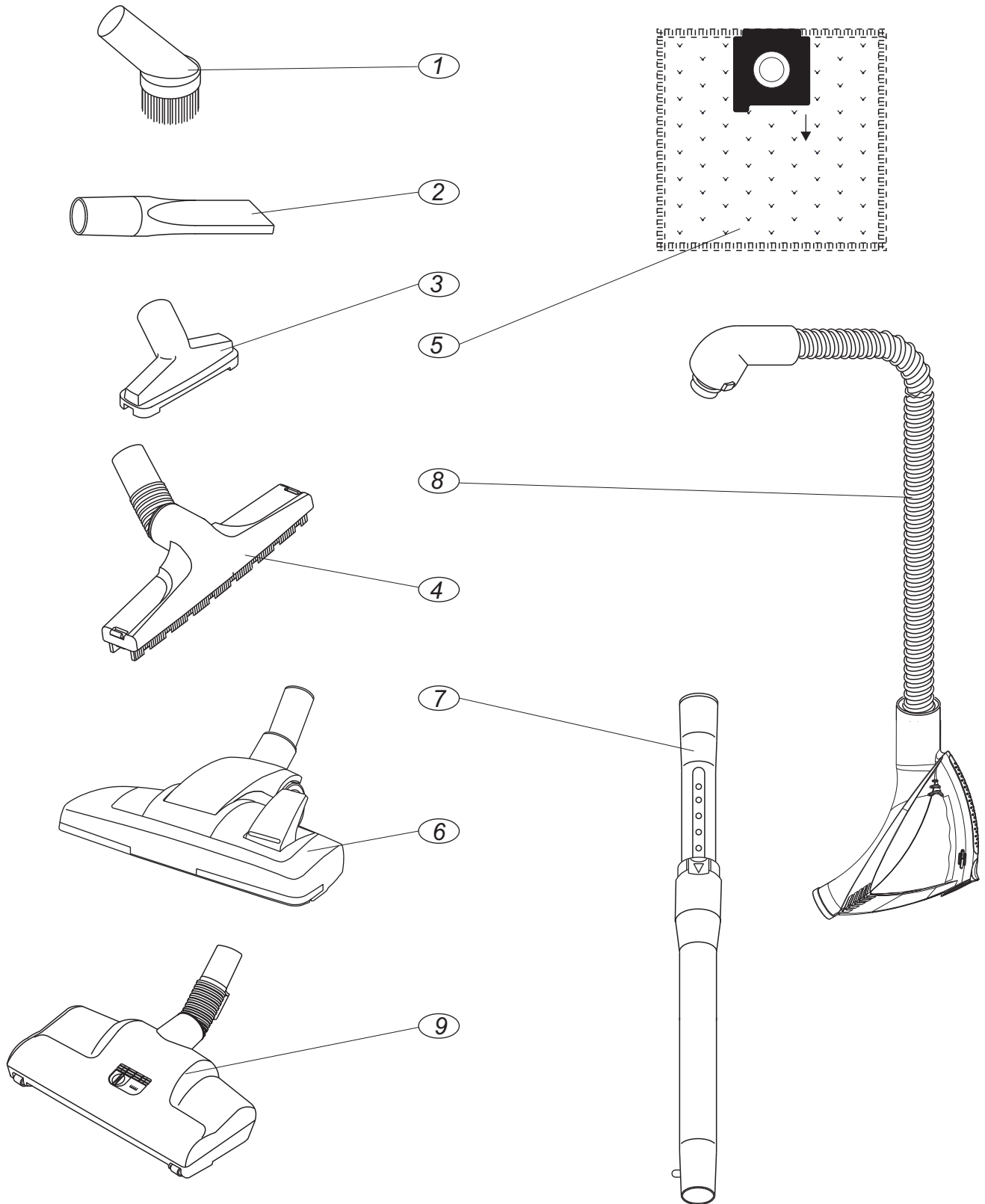

IV ELECTRICAL DIAGRAM OF THE VACUUM CLEANER ZELMER TYPE 5500.0H T AUSTRALIA

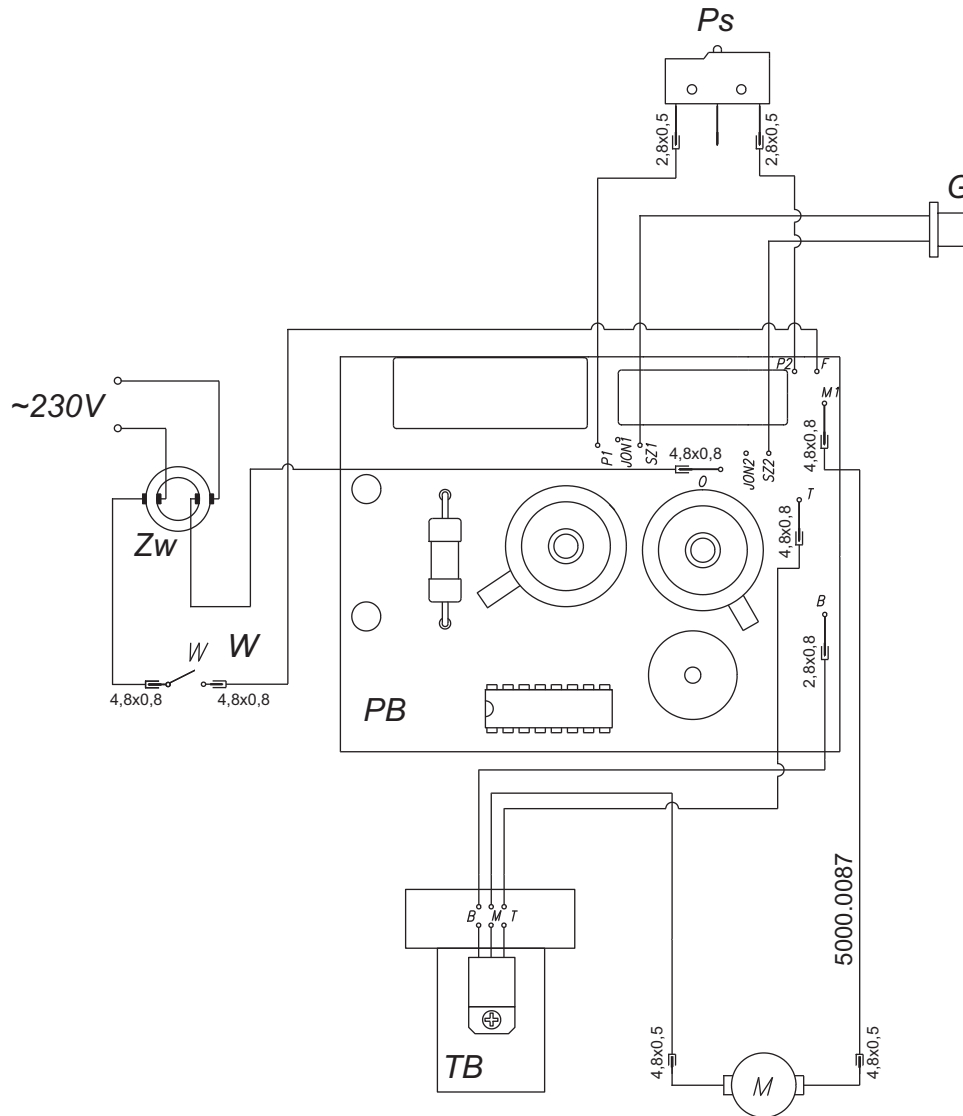

Zw - CORD WINDER
M - MOTOR
W - MAIN SWICH
TB - TRIAC BOARD
Ps - PARKSYSTEM
PB - PROCESSOR BOARD